



TITAN
HARDWARE INTERNATIONAL
 7711 AMIGOS AVE, SUITE C, DOWNEY, CA 90242
 LOCAL PH 562-803-1695 FAX 562-803-6605
 EMAIL SALES@TITANHARDWARE.COM

JCB CAP NUTS

MATERIAL = LOW CARBON STEEL

AVAILABLE PLATING

- STAT/BRONZE (SB)
- BLACK OXIDE (BW)
- BRIGHT BRASS (BB)
- ANTIQUÉ BRASS (AB)
- DULL BRASS (DB)
- NICKEL (NI)
- ZINC (CZ)
- PLAIN FINISH (RW)

PLEASE INCLUDE TWO DIGIT CODE AT END OF PART # TO SPECIFY PLATING.

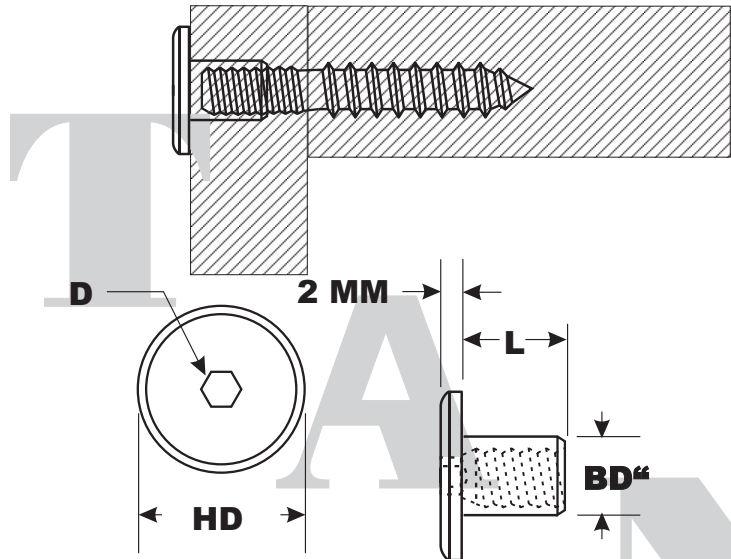

JCB NUTS ARE A LOW PROFILE COLD FORMED CAP-NUT THAT MATCH THE HEAD DIMENSIONS OF JCB BOLTS.

PART NUMBER	SIZE X L	HD	D	BD	QUANTITY PER CTN	WEIGHT PER M
NJCB-SC10-M16-S-	10-24 X 16MM	13MM	M4	.248	6,000	10 LBS
NJCB-FC04-M12-S-	1/4-20 X 12MM	17MM	M5	.350	3,500	15 LBS
NJCB-FC04-M17-S	1/4-20 X 17MM	17MM	M5	.350	3,000	18 LBS
NJCB-FC05-M17-S	5/16-18 X 17MM	17MM	M5	.430	2,500	23 LBS



TITAN
HARDWARE INTERNATIONAL
 7711 AMIGOS AVE, SUITE C, DOWNEY, CA 90242
 LOCAL PH 562-803-1695 FAX 562-803-6605
 EMAIL SALES@TITANHARDWARE.COM

ROUND BASE DIE CAST WING NUT

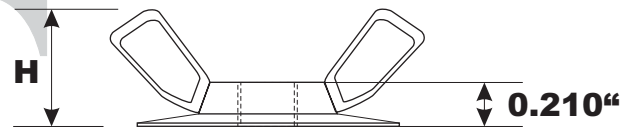
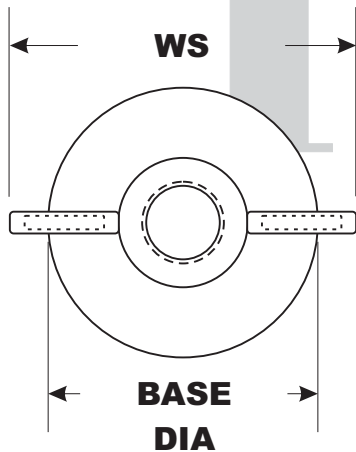

ROUND BASE WING NUTS ARE SUITED FOR A VARIETY OF APPLICATIONS. THEY HAVE A LARGE FOOTPRINT, ARE COMFORTABLE, STRONG AND ATTRACTIVE. THEY CAN BE USED ALMOST ANYWHERE A FORGED WING NUT IS USED YET OFFER A CONSIDERABLE COST ADVANTAGE.

PART NUMBER	BASE DIA	H	WS	QUANTITY PER CTN.	WEIGHT PER M
NWD-FC04-012-Z-C	1/4-20 X 3/4"	0.5"	1.0"	6,000	8.8
NWD-FC04-014-Z-C	1/4-20 X 7/8"	0.5"	1.125"	5,000	9.2

9/15/00

TOLL FREE PH 1-888-551-0456 FAX 1-888-551-0454

WWW.TITANHARDWARE.COM

004-002



TITAN
HARDWARE INTERNATIONAL
 7711 AMIGOS AVE, SUITE C, DOWNEY, CA 90242
 LOCAL PH 562-803-1695 FAX 562-803-6605
 EMAIL SALES@TITANHARDWARE.COM

DOWEL NUTS

(STEEL)

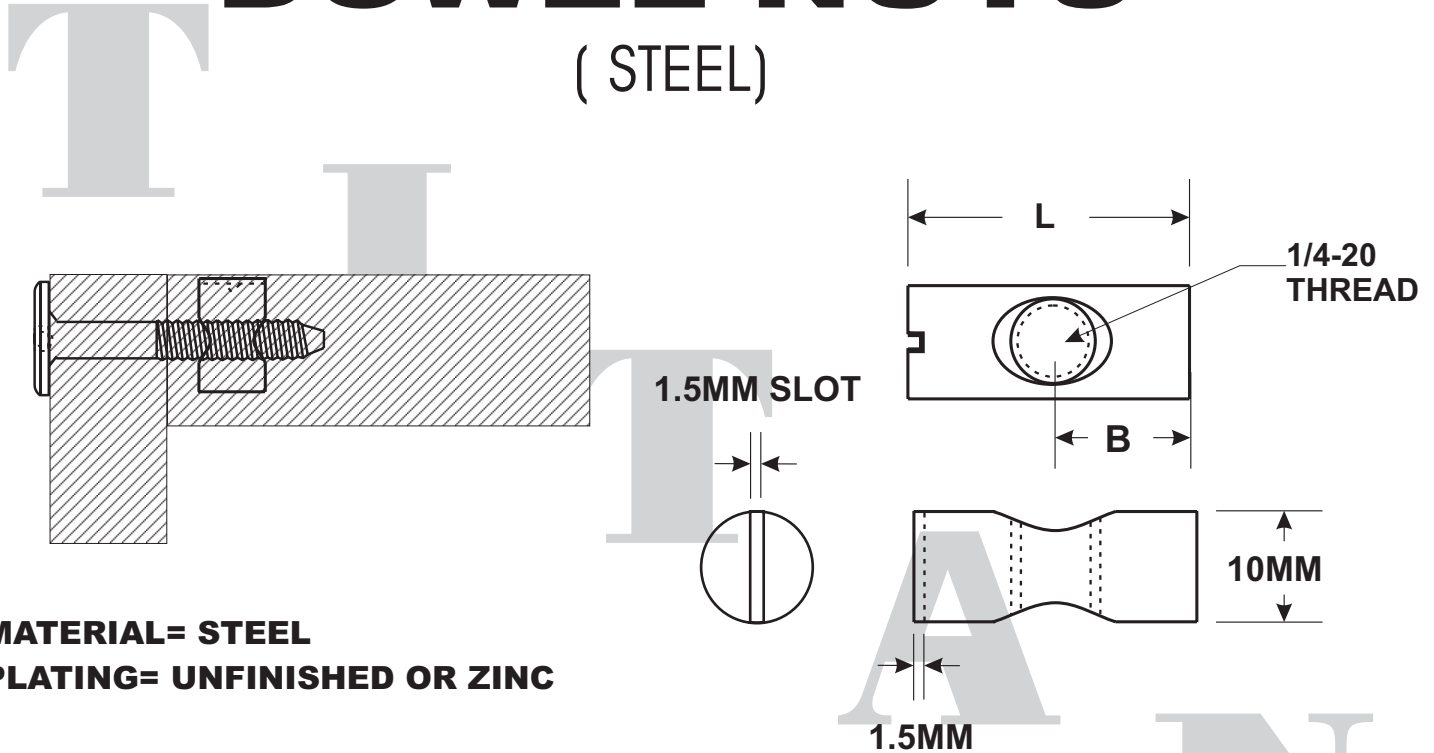

MATERIAL= STEEL
PLATING= UNFINISHED OR ZINC

OUR STEEL **DOWEL NUTS** ARE THE STRONGEST WAY TO CREATE RIGHT ANGLE JOINTS WITH THE JCB BOLTS.

PART NUMBER	SIZE	L	B	QUANTITY PER CTN.	WEIGHT PER M
NCD-FC04-M1606-S-CZ	1/4-20 X 16MM	6MM	3,000	17	
NCD-FC04-M2010-S-CZ	1/4-20 X 20MM	10MM	4,000	23	
NCD-FC04-M3010-S-CZ	1/4-20 X 30MM	10MM	1,000	37	
NCD-FC04-M3015-S-CZ	1/4-20 X 30MM	15MM	5,000	37	
NCD-FC05-M1206-S-CZ	5/16-18 X 12MM	6MM	3,000	12.6	
NCD-FC05-M1608-S-RW	5/16-18 X 16MM	8MM	3,000	21.5	

7/25/02 **TOLL FREE PH 1-888-551-0456 FAX 1-888-551-0454**

WWW.TITANHARDWARE.COM

004-003



TITAN HARDWARE INTERNATIONAL

7711 AMIGOS AVE, SUITE C, DOWNEY, CA 90242
 LOCAL PH 562-803-1695 FAX 562-803-6605
 EMAIL SALES@TITANHARDWARE.COM

DOWEL NUTS (ZINC DIE-CAST)

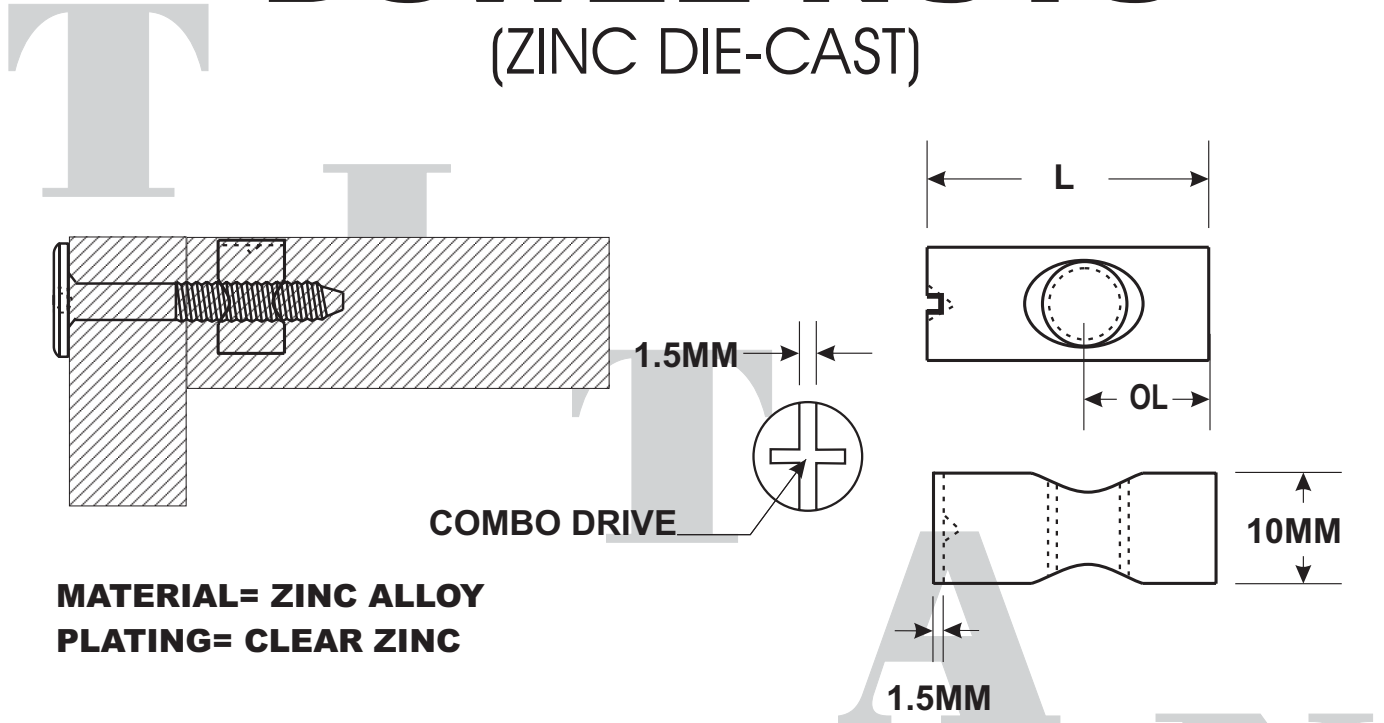

MATERIAL= ZINC ALLOY
PLATING= CLEAR ZINC

OUR ZINC ALLOY **DOWEL NUTS** ARE THE EASIEST MOST COST EFFECTIVE WAY TO CREATE RIGHT ANGLE JOINTS WITH THE JCB BOLTS. OUR HIGH QUALITY ZINC ALLOY PROVIDES STRENGTH COMPARABLE TO STEEL YET THEY ARE 20% - 30% LESS EXPENSIVE.

PART NUMBER	SIZE	L	OL	QUANTITY PER CTN.	WEIGHT PER M
NCD-F04-M13-ZDC-CZ	1/4-20 X 1/2"		6MM	7,500	8.9
NCD-F04-M15-ZDC-CZ	1/4-20 X 5/8"		6MM	5,000	10.4

PLEASE NOTE OTHER SIZES AVAILABLE UPON REQUEST. PLEASE FEEL FREE TO INQUIRE.

12/15/99 **TOLL FREE PH 1-888-551-0456 FAX 1-888-551-0454**

WWW.TITANHARDWARE.COM

004-004



TITAN
HARDWARE INTERNATIONAL
 7711 AMIGOS AVE, SUITE C, DOWNEY, CA 90242
 LOCAL PH 562-803-1695 FAX 562-803-6605
 EMAIL SALES@TITANHARDWARE.COM

T DOUBLE HOLE CROSS DOWELS

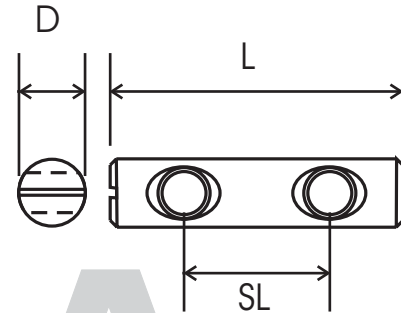
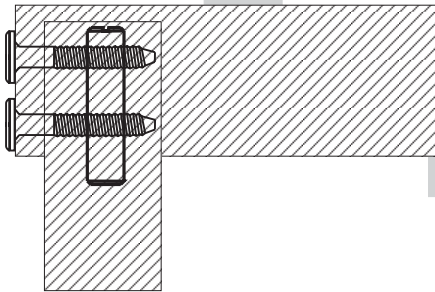

DOUBLE HOLE CROSS DOWELS ARE PERFECT FOR THOSE APPLICATIONS WHERE A EXTRA-STRONG PERPENDICULAR JOINT, SUCH AS IN ATTACHING TABLE LEGS, IS NECESSARY.

PART NUMBER	SIZE	L	D	SL	QTY./CTN	WT./M
NCD2-FC04-M45-S-CZ	1/4-20 X 44.5 MM (1.75 ")	10MM	1.25"	0.800	51	
NCD2-FC05-M50-S-CZ	5/16-18 X 50 MM (1.96 ")	12MM	1.25"	0.500	82	

7/25/02

TOLL FREE PH 1-888-551-0456 FAX 1-888-551-0454
WWW.TITANHARDWARE.COM

004-005



TITAN
HARDWARE INTERNATIONAL
 7711 AMIGOS AVE, SUITE C, DOWNEY, CA 90242
 LOCAL PH 562-803-1695 FAX 562-803-6605
 EMAIL SALES@TITANHARDWARE.COM

T 4 PRONG STEEL T-NUTS

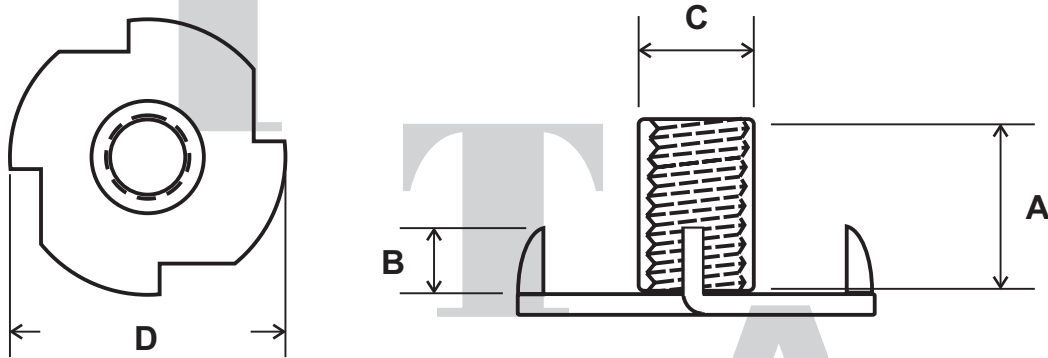

OUR 4 PRONG T-NUTS OFFER AN FAST ECONOMICAL WAY TO APPLY A THREADED HOLE INTO WOOD. THE 4 PRONGS ALLOW FOR AN EVEN APPLICATION INTO HARD AND SOFT WOODS.

PART #	THREAD & A	B	C	D	QTY/CTN	LBS/M
NT4-FC04-05-S-CZ	1/4-20 X 5/16"	7/32"	.305"	3/4"	4,000	7.5
NT4-FC04-07-S-CZ	1/4-20 X 7/16"	7/32"	.305"	3/4"	3,500	8.5
NT4-FC04-09-S-PL	1/4-20 X 9/16"	7/32"	.305"	3/4"	3,000	10
NT4-FC05-06-S-PL	5/16-18X 3/8"	1/4"	.390"	7/8"	2,500	10.4
NT4-FC05-10-S-PL	5/16-18X 5/8"	1/4"	.390"	7/8"	2,500	18.8

12/13/99

TOLL FREE PH 1-888-551-0456 FAX 1-888-551-0454
WWW.TITANHARDWARE.COM

004-006



TITAN
HARDWARE INTERNATIONAL
 7711 AMIGOS AVE, SUITE C, DOWNEY, CA 90242
 LOCAL PH 562-803-1695 FAX 562-803-6605
 EMAIL SALES@TITANHARDWARE.COM

TITAN PROPELLER NUTS

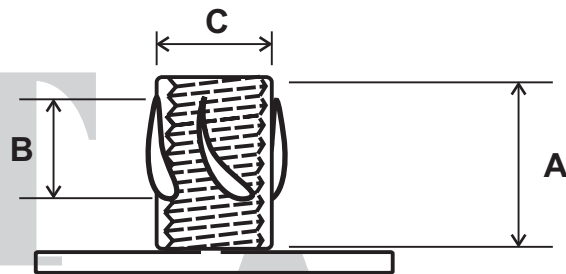
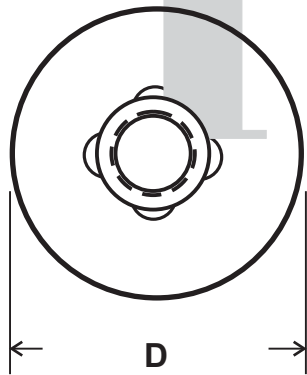

PROPELLER NUTS OFFER FAST EVEN INSTALLATIONS IN ALL TYPES OF WOOD. THESE ARE THE PERFECT CHOICE WHEN PULL-OUT IS NOT AN ISSUE.

PART #	THREAD & A	B	C	D	QTY/CTN	LBS/M
NPL-SC10-05-S-RW	10-24 X 5/16"	.118	.245"	3/4"	5,000	7
NPL-FC04-07-S-RW	1/4-20 X 7/16"	3/16"	.312"	3/4"	5,000	9
NPL-FC04-08-S-RW	1/4-20 X 1/2"	13/64"	.312"	5/8"	5,000	9
NPL-FC05-10-S-RW	5/16-18X 5/8"	7/32"	.390"	7/8"	2,500	18

PLEASE NOTE OTHER SIZES AVAILABLE UPON REQUEST. PLEASE FEEL FREE TO INQUIRE.

01/07/02

TOLL FREE PH 1-888-551-0456 FAX 1-888-551-0454
WWW.TITANHARDWARE.COM

004-007



TITAN
HARDWARE INTERNATIONAL
 7711 AMIGOS AVE, SUITE C, DOWNEY, CA 90242
 LOCAL PH 562-803-1695 FAX 562-803-6605
 EMAIL SALES@TITANHARDWARE.COM

SLAB AND ROUND BASE WELD NUTS

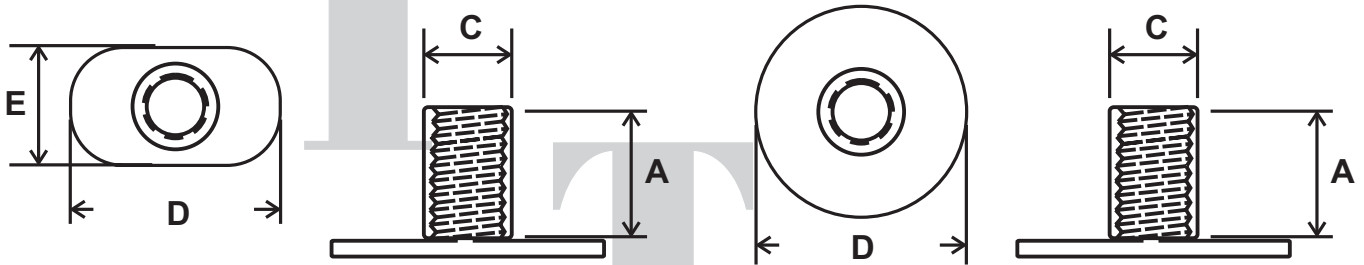

**SLAB BASE
 TYPE NWSL**

**ROUND BASE
 TYPE NWR**

SLAB OR ROUND BASE WELD NUTS CAN BE WELDED ONTO METAL OR MOLDED INTO PLASTIC. OR, THEY CAN BE USED AS A SUBSTITUTE FOR T-NUTS WHEN PULL-OUT AND SPIN-OUT ARE NOT ISSUES.

PART #	THREAD & A	C	D	E	QTY/CTN	LBS/M
NWR-SC06-04-09-S-RW	6-32 X 9/32"	.162"	9/16"	N/A	15,000	3
NWSL-SC10-09-12-S-CZ	10-24 X 9/32"	.243"	3/4"	1/2"	5,000	6
NWSL-FC05-11-08-S-CZ	5/16-18 X 11/32"	.390"	1 1/4"	1/2"	2,000	15

01/23/02

TOLL FREE PH 1-888-551-0456 FAX 1-888-551-0454

WWW.TITANHARDWARE.COM

004-008



TITAN
HARDWARE INTERNATIONAL
 7711 AMIGOS AVE, SUITE C, DOWNEY, CA 90242
 LOCAL PH 562-803-1695 FAX 562-803-6605
 EMAIL SALES@TITANHARDWARE.COM

ROUND TUBE WELD NUTS

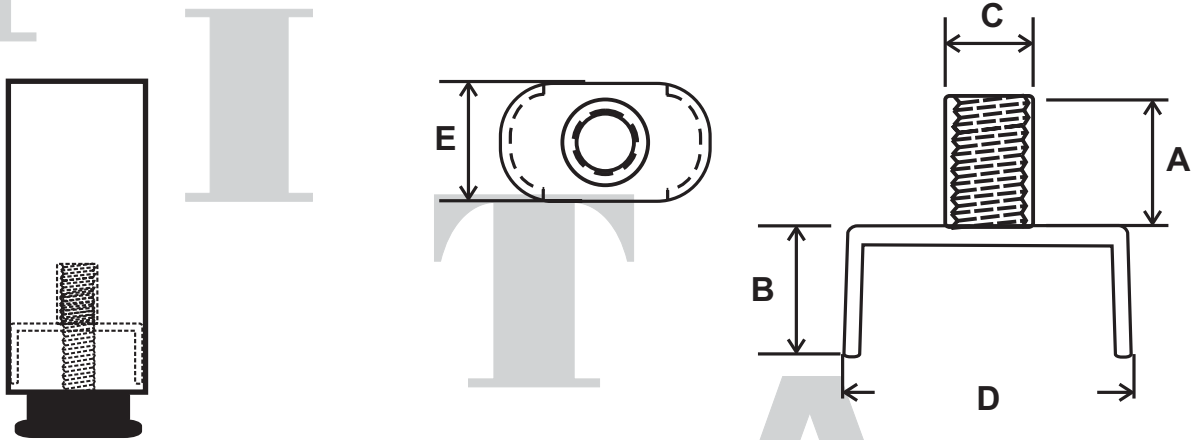

ROUND TUBE WELD NUTS ARE USED TO APPLY THREADS TO THE INSIDE OF ROUND STEEL TUBES, SUCH AS IN THE CASE OF A ROUND STEEL LEG FOR FURNITURE. THEY PROVIDE A SUPER STRONG WAY TO INSTALL HEAVY DUTY GLIDES AND CASTERS.

PART #	THREAD & D	C	B	A	E	QTY/CTN	LBS/M
NWRT-FC05-D113-S-RW	5/16-18 X .113"	.379"	.421"	.378"	.496"	2,000	17
NWRT-FC05-D136-S-RW	5/16-18 X .136"	.379"	.421"	.378"	.496"	2,000	19

PLEASE NOTE OTHER SIZES AVAILABLE UPON REQUEST. PLEASE FEEL FREE TO INQUIRE.

01/07/02

TOLL FREE PH 1-888-551-0456 FAX 1-888-551-0454

WWW.TITANHARDWARE.COM

004-009



TITAN
HARDWARE INTERNATIONAL
 7711 AMIGOS AVE, SUITE C, DOWNEY, CA 90242
 LOCAL PH 562-803-1695 FAX 562-803-6605
 EMAIL SALES@TITANHARDWARE.COM

SHELF SUPPORTS

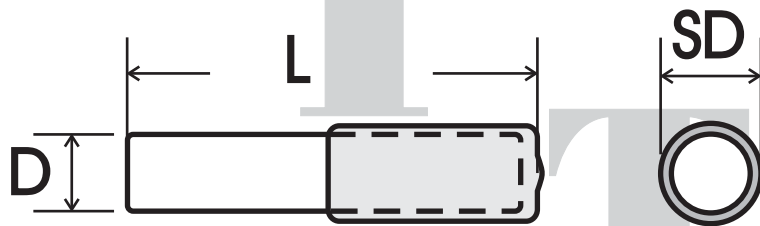

TYPE PSG
GLASS SHELF SUPPORT
ZINC PLATED WITH BLACK
VINYL CAP

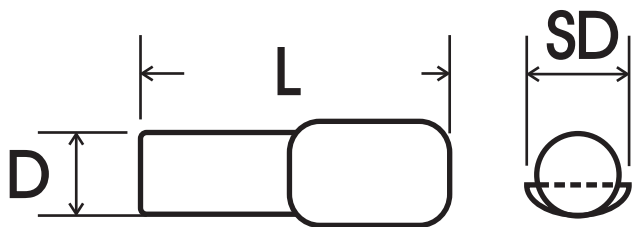

TYPE PSS
SPOON SHELF SUPPORT
ZINC YELLOW PLATED

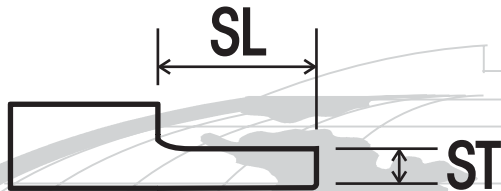

MATERIAL = LOW CARBON STEEL

PART NUMBER	DISCRIPTION DXL	SD	SL	ST	CTN. QTY.	LBS/M
PSG-M05-M025-SZ-VB	M5 X 25MM	N/A	N/A	N/A	4,000	8.8
PSS-M05-M020-S-YZ	M5 X 20MM	1/4"	3/8"	.108	4,000	6.2
PSS-F04-M020-S-YZ	1/4 X 20MM	5/16"	3/8"	.126	3,000	9.8

PLEASE NOTE OTHER SIZES AVAILABLE UPON REQUEST. PLEASE FEEL FREE TO INQUIRE.

TOLL FREE PH 1-888-551-0456 FAX 1-888-551-0454

WWW.TITANHARDWARE.COM

005-001