



TITAN HARDWARE INTERNATIONAL

7711 AMIGOS AVE, SUITE C, DOWNEY, CA 90242
 LOCAL PH 562-803-1695 FAX 562-803-6605
 EMAIL SALES@TITANHARDWARE.COM

JC "BW" SCREWS

MATERIAL = LOW CARBON STEEL

AVAILABLE PLATING

- STAT/BRONZE (SB)
- BLACK OXIDE (BW)
- BRIGHT BRASS (DB)
- ANTIQUE BRASS (AB)
- NICKEL (NI)
- ZINC (CZ)
- PLAIN FINISH (RW)

**PLEASE INCLUDE TWO DIGIT
 CODE AT END OF PART # TO
 SPECIFY PLATING.**

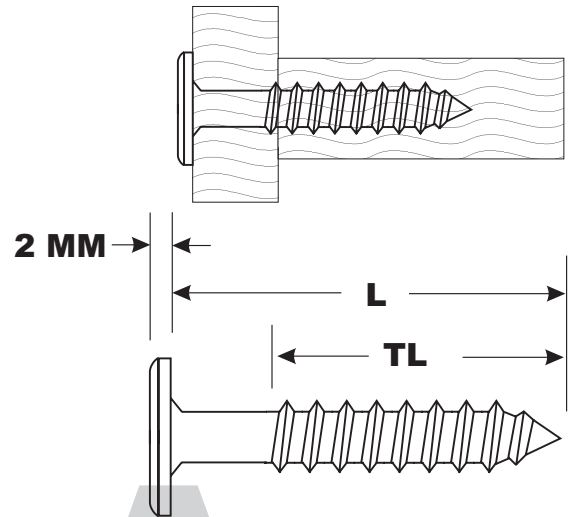
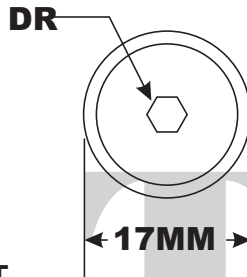

JCBW SCREWS ARE A LOW PROFILE HIGH QUALITY DECORATIVE FASTENER. USED IN PRE-DRILLED HOLES THEY FORM EXTREMELY STRONG, EASY TO ASSEMBLE RIGHT ANGLE JOINTS.

PART NUMBER	SIZE	L	TL	DR	QTY PER CTN	WEIGHT PER M
JCBW-SM07-M040-S-	M7 X 40 MM (1.575")		30MM	M4	1,600	22
JCBW-SM07-M050-S-	M7 X 50 MM (1.969")		40MM	M4	1,500	26
JCBW-SM07-M060-S-	M7 X 60 MM (2.362")		50MM	M4	1,200	30
JCBW-SM07-M070-S-	M7 X 70 MM (2.756")		60MM	M4	1,000	34
JCBW-SM07-M080-S-	M7 X 80 MM (3.150")		65MM	M4	700	40
JCBW-SM07-M090-S-	M7 X 90 MM (3.543")		70MM	M5	600	42
JCBW-SM07-M100-S-	M7 X 100 MM (3.937")		70MM	M6	500	48



TITAN HARDWARE INTERNATIONAL

7711 AMIGOS AVE, SUITE C, DOWNEY, CA 90242
 LOCAL PH 562-803-1695 FAX 562-803-6605
 EMAIL SALES@TITANHARDWARE.COM

JC "CW" SCREWS

MATERIAL = LOW CARBON STEEL

AVAILABLE PLATING

- STAT/BRONZE (SB)
- BLACK OXIDE (BW)
- BRIGHT BRASS (DB)
- ANTIQU BRASS (AB)
- NICKEL (NI)
- ZINC (CZ)
- PLAIN FINISH (RW)

**PLEASE INCLUDE TWO DIGIT
 CODE AT END OF PART # TO
 SPECIFY PLATING.**

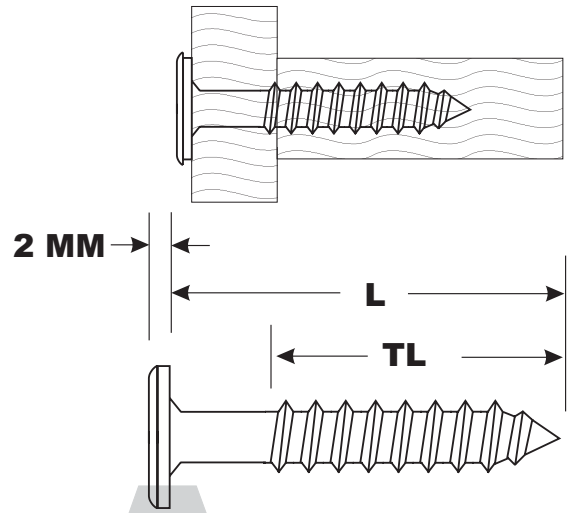
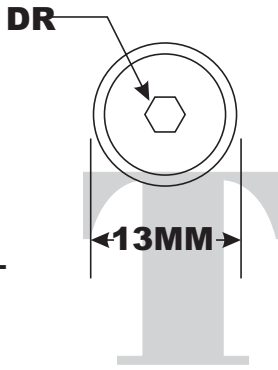

JCBW SCREWS ARE A LOW PROFILE HIGH QUALITY DECORATIVE FASTENER. USED IN PRE-DRILLED HOLES THEY FORM EXTREMELY STRONG, EASY TO ASSEMBLE RIGHT ANGLE JOINTS.

PART NUMBER	SIZE	L	TL	DR	QTY PER CTN	WEIGHT PER M
JCCW-SM07-M040-S-	M7 X 40 MM (1.575")		30MM	M4	1,600	22
JCCW-SM07-M050-S-	M7 X 50 MM (1.969")		40MM	M4	1,400	26
JCCW-SM07-M060-S-	M7 X 60 MM (2.362")		50MM	M4	1,200	30
JCCW-SM07-M070-S-	M7 X 70 MM (2.756")		60MM	M4	1,000	32

PLEASE NOTE OTHER SIZES AVAILABLE UPON REQUEST. PLEASE FEEL FREE TO INQUIRE.



TITAN HARDWARE INTERNATIONAL

7711 AMIGOS AVE, SUITE C, DOWNEY, CA 90242
 LOCAL PH 562-803-1695 FAX 562-803-6605
 EMAIL SALES@TITANHARDWARE.COM

JCSE SCREWS

MATERIAL = LOW CARBON STEEL

AVAILABLE PLATING

- STAT/BRONZE (SB)
- BLACK OXIDE (BW)
- BRIGHT BRASS (DB)
- ANTIQU BRASS (AB)
- NICKEL (NI)
- ZINC (CZ)
- PLAIN FINISH (RW)

**PLEASE INCLUDE TWO DIGIT
 CODE AT END OF PART # TO
 SPECIFY PLATING.**

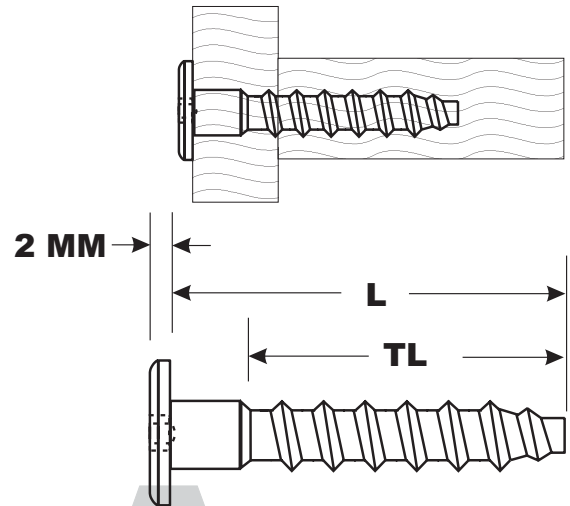
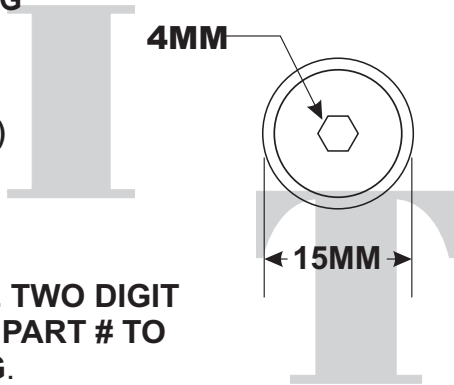

JCSE SCREWS ARE A LOW PROFILE HIGH QUALITY DECORATIVE FASTENER. USED IN PRE-DRILLED HOLES THEY ARE USED WHERE CLOSE TOLERANCE RIGID JOINTS ARE REQUIRED ,SUCH AS IN CHAIR ARM JOINTS..

PART NUMBER	SIZE	L	TL	QUANTITY PER CTN	WEIGHT PER M
JCSE-SM07-M070-S-	M7 X 70 MM (2.756")		60MM	1,000	34

PLEASE NOTE OTHER SIZES AVAILABLE UPON REQUEST. PLEASE FEEL FREE TO INQUIRE.



TITAN
HARDWARE INTERNATIONAL
 7711 AMIGOS AVE, SUITE C, DOWNEY, CA 90242
 LOCAL PH 562-803-1695 FAX 562-803-6605
 EMAIL SALES@TITANHARDWARE.COM

CONNECTING SCREWS

MATERIAL = LOW CARBON STEEL

AVAILABLE PLATING

- STAT/BRONZE (SB)
- BLACK OXIDE (BW)
- BRIGHT BRASS (DB)
- ANTIQUE BRASS (AB)
- NICKEL (NI)
- ZINC (CZ)
- PLAIN FINISH (RW)

PLEASE INCLUDE TWO DIGIT CODE AT END OF PART # TO SPECIFY PLATING.

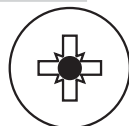
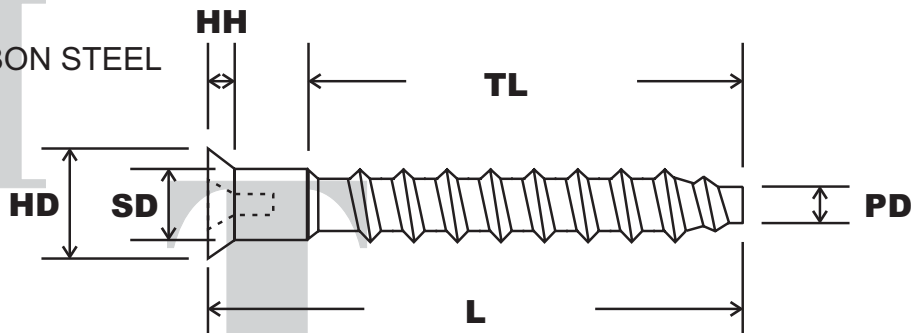

POZI-DRIVE W/HOLE



HEX DRIVE W/HOLE

M5 DIA HAS 3MM DRIVE
 M7 DIA HAS 4MM DRIVE

CONNECTING SCREWS ARE A FLUSH MOUNTING POSITIVE GRIPPING FASTENER. USED IN PRE-DRILLED HOLES, THEY FORM EXTREMELY STRONG, EASY TO ASSEMBLE RIGHT ANGLE JOINTS.

PART NUMBER	SIZE	L	DRIVE	TL	QUANTITY PER CTN	WEIGHT PER M
CSP-SM05-M040-S-	M5 X 40 MM (1.575")		POZI	30MM	4,000	10
CSP-SM05-M050-S-	M5 X 50 MM (1.969")		POZI	40MM	4,000	11
CSH-SM05-M050-S-	M5 X 50 MM (1.969")		HEX	40MM	4,000	11
CSP-SM07-M050-S-	M7 X 50 MM (1.969")		POZI	40MM	1,500	24
CSH-SM07-M050-S-	M7 X 50 MM (1.969")		HEX	40MM	1,500	24
CSP-SM07-M070-S-	M7 X 70 MM (2.756")		POZI	60MM	1,000	31
CSH-SM07-M070-S-	M7 X 70 MM (2.756")		HEX	60MM	1,000	31

07/25/02 **TOLL FREE PH 1-888-551-0456 FAX 1-888-551-0454**

WWW.TITANHARDWARE.COM

002-004



TITAN HARDWARE INTERNATIONAL

7711 AMIGOS AVE, SUITE C, DOWNEY, CA 90242
LOCAL PH 562-803-1695 FAX 562-803-6605
EMAIL SALES@TITANHARDWARE.COM

CONNECTING SCREWS

SHARP POINT WITH NIBS

MATERIAL = LOW CARBON STEEL

AVAILABLE PLATING

STAT/BRONZE (SB)
BLACK OXIDE (BW)
BRIGHT BRASS (DB)
ANTIQUE BRASS (AB)
NICKEL (NI)
ZINC (CZ)
PLAIN FINISH (RW)

**PLEASE INCLUDE TWO DIGIT
CODE AT END OF PART # TO
SPECIFY PLATING.**

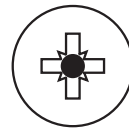
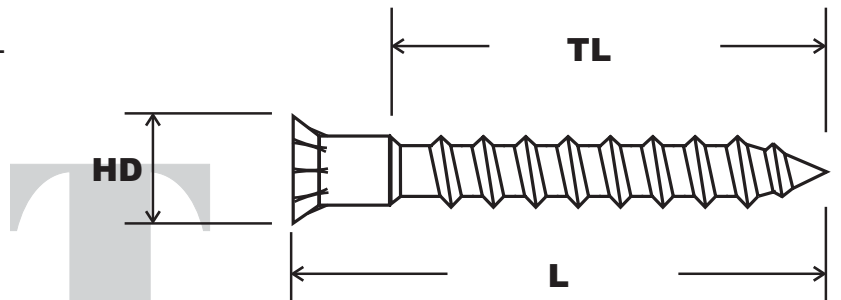

**POZI-DRIVE
W/HOLE**



**HEX DRIVE
W/HOLE**

M7 DIA HAS 4MM DRIVE

CONNECTING SCREWS ARE A FLUSH MOUNTING POSITIVE GRIPPING FASTENER THAT INCLUDE SELF COUNTERSINKING NIBS UNDERNIETH THE HEAD.

PART NUMBER	SIZE	L	DRIVE	TL	QUANTITY PER CTN	WEIGHT PER M
CSPA-SM07-M050-S-	M7 X 50 MM (1.969")		POZI	40MM	1,500	24
CSHA-SM07-M050-S-	M7 X 50 MM (1.969")		HEX	40MM	1,500	24

PLEASE NOTE OTHER SIZES AVAILABLE UPON REQUEST. PLEASE FEEL FREE TO INQUIRE.

01/13/04 **TOLL FREE PH 1-888-551-0456 FAX 1-888-551-0454**

WWW.TITANHARDWARE.COM

002-005



TITAN HARDWARE INTERNATIONAL

7711 AMIGOS AVE, SUITE C, DOWNEY, CA 90242
LOCAL PH 562-803-1695 FAX 562-803-6605
EMAIL SALES@TITANHARDWARE.COM

HANGER BOLTS

MATERIAL = LOW CARBON STEEL

AVAILABLE PLATING

ZINC (CZ)

PLAIN FINISH (RW)

**PLEASE INCLUDE TWO DIGIT
CODE AT END OF PART # TO
SPECIFY PLATING.**

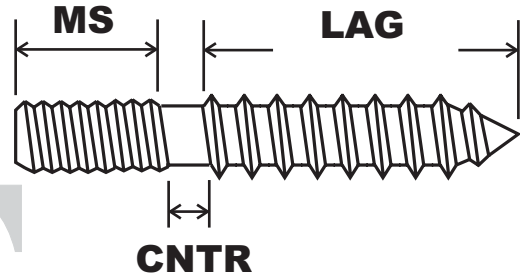

PART NUMBER	SIZE X L	MS	LAG	CNTR	QUANTITY PER CTN	WEIGHT PER M
BHF-FC04-024-S--	1/4-20 X 1 1/2"	5/8"	7/8"	NONE	1,500	14.0
BHF-FC04-028-S--	1/4-20 X 1 3/4"	3/4"	1"	NONE	1,000	16.7
BHF-FC04-032-S--	1/4-20 X 2"	1"	1"	NONE	1,000	18.3
BHF-FC04-036-S--	1/4-20 X 2 1/4"	1"	1 1/4"	NONE	1,000	21.7
BHF-FC04-040-S--	1/4-20 X 2 1/2"	1"	1 1/2"	NONE	1,000	23.2
BHF-FC04-044-S--	1/4-20 X 2 3/4"	1 1/4"	1 1/2"	NONE	750	26.8
BHF-FC04-048-S--	1/4-20 X 3"	1 1/2"	1 1/2"	NONE	700	28.6
BHF-FC04-056-S--	1/4-20 X 3 1/2"	1 1/2"	2"	NONE	500	33.9
BHF-FC04-064-S--	1/4-20 X 4"	2"	2"	NONE	500	38.7
BHF-FC04-072-S--	1/4-20 X 4 1/2"	1 1/8"	3"	3/8"	350	44.2
BHF-FC04-080-S--	1/4-20 X 5"	1 3/8"	3"	5/8"	300	49.0
BHF-FC04-088-S--	1/4-20 X 5 1/2"	1 1/2"	3"	1 "	250	53.1
BHF-FC04-096-S--	1/4-20 X 6"	1 1/2"	3"	1 1/2"	250	59.2
BHF-FC05-024-S--	5/16-18 X 1 1/2"	5/8"	7/8"	NONE	1,000	22.1
BHF-FC05-028-S--	5/16-18 X 1 3/4"	3/4"	1"	NONE	1,000	25.9
BHF-FC05-032-S--	5/16-18 X 2"	1"	1"	NONE	1,000	30.4
BHF-FC05-036-S--	5/16-18 X 2 1/4"	1"	1 1/4"	NONE	700	34.2
BHF-FC05-040-S--	5/16-18 X 2 1/2"	1"	1 1/2"	NONE	700	38.0
BHF-FC05-044-S--	5/16-18 X 2 3/4"	1 1/4"	1 1/2"	NONE	500	42.6
BHF-FC05-048-S--	5/16-18 X 3"	1 1/2"	1 1/2"	NONE	500	46.1
BHF-FC05-056-S--	5/16-18 X 3 1/2"	1 1/2"	2"	NONE	500	54.1
BHF-FC05-064-S--	5/16-18 X 4"	2"	2"	NONE	400	65.0
BHF-FC05-072-S--	5/16-18 X 4 1/2"	1 1/8"	3"	3/8"	350	72.0
BHF-FC04-080-S--	5/16-18 X 5"	1 3/8"	3"	5/8"	250	82.6
BHF-FC04-088-S--	5/16-18 X 5 1/2"	1 1/2"	3"	1 "	250	87.9
BHF-FC04-096-S--	5/16-18 X 6"	1 1/2"	3"	1 1/2"	200	95.2



TITAN
HARDWARE INTERNATIONAL
 7711 AMIGOS AVE, SUITE C, DOWNEY, CA 90242
 LOCAL PH 562-803-1695 FAX 562-803-6605
 EMAIL SALES@TITANHARDWARE.COM

T DOWEL SCREW

MATERIAL = LOW CARBON STEEL

AVAILABLE PLATING

ZINC (CZ)
 PLAIN FINISH (RW)

**PLEASE INCLUDE TWO DIGIT
 CODE AT END OF PART # TO
 SPECIFY PLATING.**

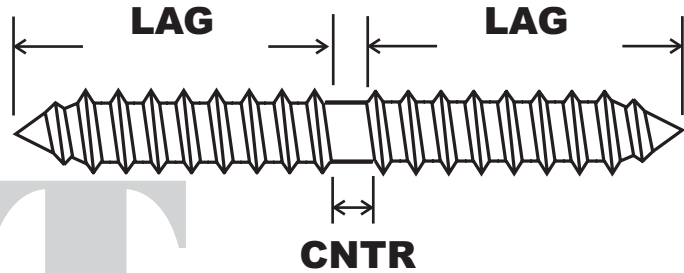

PART NUMBER	SIZE X L	LAG	LAG	CNTR	QUANTITY PER CTN	WEIGHT PER M
DSF-S04-024-S--	1/4-10 X 1 1/2"	3/4"	3/4"	NONE	1,500	12.7
DSF-S04-028-S--	1/4-10 X 1 3/4"	3/4"	3/4"	1/4"	1,000	15.8
DSF-S04-032-S--	1/4-10 X 2"	7/8"	7/8"	1/4"	1,000	18.6
DSF-S04-040-S--	1/4-10 X 2 1/2"	1 1/8"	1 1/8"	1/4"	1,000	23.9
DSF-S04-048-S--	1/4-10 X 3"	1 3/8"	1 3/8"	1/4"	700	28.6
DSF-S04-056-S--	1/4-10 X 3 1/2"	1 5/8"	1 5/8"	1/4"	500	34.1
DSF-S05-024-S--	5/16-9 X 1 1/2"	3/4"	3/4"	NONE	1,000	22.1
DSF-S05-028-S--	5/16-9 X 1 3/4"	3/4"	3/4"	1/4"	1,000	25.9
DSF-S05-032-S--	5/16-9 X 2"	7/8"	7/8"	1/4"	1,000	30.4
DSF-S05-040-S--	5/16-9 X 2 1/2"	1 1/8"	1 1/8"	1/4"	700	37.8
DSF-S05-048-S--	5/16-9 X 3"	1 3/8"	1 3/8"	1/4"	500	46.3



TITAN
HARDWARE INTERNATIONAL
7711 AMIGOS AVE, SUITE C, DOWNEY, CA 90242
LOCAL PH 562-803-1695 FAX 562-803-6605
EMAIL SALES@TITANHARDWARE.COM

EURO SCREWS

MATERIAL = STEEL
AVAILABLE PLATING
ZINC

PLEASE INCLUDE TWO DIGIT
CODE AT END OF PART # TO
SPECIFY PLATING.

POZI-DRIVE

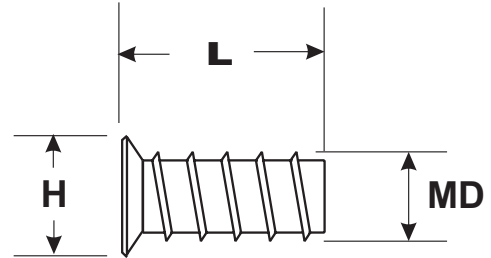
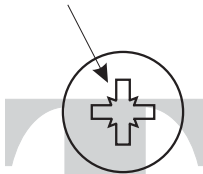

EURO SCREWS ARE DESIGNED TO BE USED IN PREDRILLED DRAWER GLIDE APPLICATIONS WHERE A LOW PROFILE HEAD IS A MUST.

PART NUMBER	SIZE & L	H	QUANTITY PER CTN.	WEIGHT PER M
TSE-M6.3-M10.5-ZF-S-CZ	M6.3 X 10.5MM	7MM	10M	3.2 LBS
TSE-M6.3-M13-ZF-S-CZ	M6.3 X 13MM	7MM	10M	3.8 LBS
TSE-M6.3-M14-ZF-S-CZ	M6.3 X 14MM	7MM	10M	4.0 LBS

PLEASE NOTE OTHER SIZES AVAILABLE UPON REQUEST. PLEASE FEEL FREE TO INQUIRE.

04/04/03 **TOLL FREE PH 1-888-551-0456 FAX 1-888-551-0454**

WWW.TITANHARDWARE.COM

002-008



TITAN
HARDWARE INTERNATIONAL
7711 AMIGOS AVE, SUITE C, DOWNEY, CA 90242
LOCAL PH 562-803-1695 FAX 562-803-6605
EMAIL SALES@TITANHARDWARE.COM

PULL SCREWS

MATERIAL = STEEL
AVAILABLE PLATING
ZINC (CZ)
BLACK OXIDE (BW)

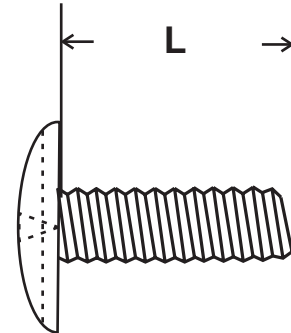
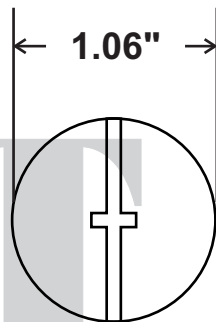

**PLEASE INCLUDE TWO DIGIT
CODE AT END OF PART # TO
SPECIFY PLATING.**

PULL SCREWS ARE USED FOR HOLDING DRAWER PULLS ON DRAWER FRONTS. THEY HAVE A COMBINATION DRIVE FOR EASY INSTALLATION. .

PART NUMBER	SIZE & L	QUANTITY PER CTN.	WEIGHT PER M
MS-SC08-016-CT-S-	8-32 X 1"	8M	6.2
MS-SC08-018-CT-S-	8-32 X 1 1/8"	7.5M	6.7
MS-SC08-020-CT-S-	8-32 X 1 1/4"	7M	7.2
MS-SC08-022-CT-S-	8-32 X 1 3/8"	7M	7.8
MS-SC08-024-CT-S-	8-32 X 1 1/2"	6M	8.3

PLEASE NOTE OTHER SIZES AVAILABLE UPON REQUEST. PLEASE FEEL FREE TO INQUIRE.

9/15/00 **TOLL FREE PH 1-888-551-0456 FAX 1-888-551-0454**

WWW.TITANHARDWARE.COM

002-009



TITAN
HARDWARE INTERNATIONAL
 7711 AMIGOS AVE, SUITE C, DOWNEY, CA 90242
 LOCAL PH 562-803-1695 FAX 562-803-6605
 EMAIL SALES@TITANHARDWARE.COM

CABINET CONNECTORS

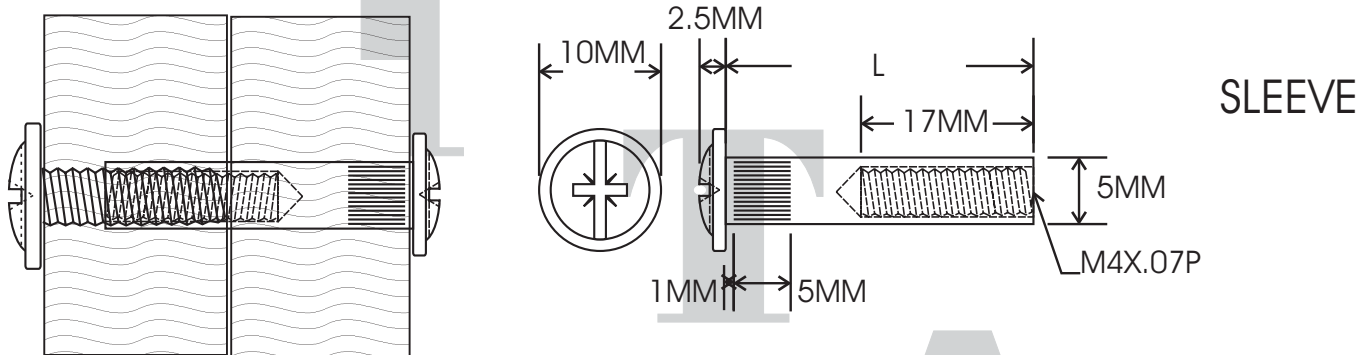

SLEEVE

MATERIAL = LOW CARBON STEEL
 STANDARD PLATING IS
 BLACK OXIDE HOWEVER, OTHER
 PLATINGS ARE AVAILABLE UPON
 REQUEST.

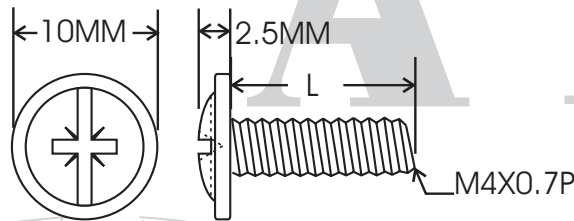

SCREW

CABINET CONNECTORS ARE USED TO CONNECT TWO PIECES OF FURNITURE TOGETHER. THEY COME WITH A 5MM OUTSIDE DIAMETER, SO THEY FIT PERFECTLY IN THE 5MM HOLES MADE FOR SHELF SUPPORTS. THE SCREWS ARE ALSO THE PERFECT SIZE FOR METRIC DRAWER PULLS.

PART NUMBER	DISCRIPTION	"L"	CTN. QTY.	LBS/M
SBKF-MC4-35-CMT-S-BW	SLEEVE	35MM (1 3/8")	2,500	9.0 LBS
SBKM-MC4-15-CMT-S-BW	SCREW	15MM (9/16")	2,500	3.2 LBS
SBKM-MC4-22-CMT-S-BW	SCREW	22MM (7/8")	2,500	5.5 LBS
SBKM-MC4-25-CMT-S-BW	SCREW	25MM (1")	2,500	5.7 LBS
SBKM-MC4-28-CMT-S-BW	SCREW	28MM (1 1/8")	2,500	6.1 LBS
SBKM-MC4-32-CMT-S-BW	SCREW	32MM (1 1/4")	2,500	7.0 LBS
SBKM-MC4-38-CMT-S-BW	SCREW	38MM (1 1/2")	2,500	8.0 LBS

PLEASE NOTE OTHER SIZES AVAILABLE UPON REQUEST. PLEASE FEEL FREE TO INQUIRE.

01/02/02 **TOLL FREE PH 1-888-551-0456 FAX 1-888-551-0454**

WWW.TITANHARDWARE.COM

002-010



TITAN
HARDWARE INTERNATIONAL
 7711 AMIGOS AVE, SUITE C, DOWNEY, CA 90242
 LOCAL PH 562-803-1695 FAX 562-803-6605
 EMAIL SALES@TITANHARDWARE.COM

GRAB-TITE SCREWS™

PAN HEADS

MATERIAL = HEAT TREATED STEEL

AVAILABLE PLATING

BLACK OXIDE (BW)
 ZINC (CZ)

PLEASE INCLUDE TWO DIGIT CODE AT END OF PART # TO SPECIFY PLATING.

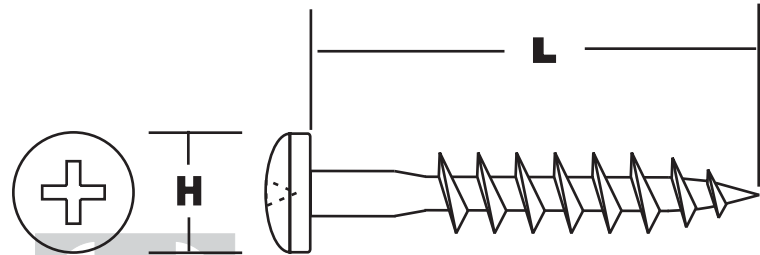

GRAB-TITE PARTICLE BOARD SCREWS COMBINE THE BEST FEATURES OF DRYWALL SCREWS AND WOOD SCREWS IN ONE FASTENER. THEY ARE FULL BODY AND HARDENED FOR SUPERIOR STRENGTH. THEY HAVE DEEP, COARSE THREADS FOR FAST DRIVING AND SUPERIOR HOLDING STRENGTH, AND THEY ALSO HAVE SELF COUNTERSINKING NIBS UNDERNEATH THE HEAD. ALL THESE FEATURES MAKE THE PERFECT SCREWS FOR FINISH CARPENTRY WORK.

PART NUMBER	SIZE & L	H	QUANTITY PER CTN.	WEIGHT. PER LBS
PBS-S06-010-PP-S-	6 X 5/8"	.285	18,000	2.8 LBS
PBS-S08-010-PP-S-	8 X 5/8"	.315	15,000	3.3 LBS
PBS-S08-012-PP-S-	8 X 3/4"	.315	12,000	3.7 LBS
PBS-S08-016-PP-S-	8 X 1"	.315	10,000	4.5 LBS
PBS-S08-020-PP-S-	8 X 1 1/4"	.315	10,000	5.2 LBS
PBS-S10-010-PP-S-	10 X 5/8"	.365	10,000	4.4 LBS
PBS-S10-012-PP-S-	10 X 3/4"	.365	8,000	4.8 LBS
PBS-S10-016-PP-S-	10 X 1"	.365	7,000	5.8 LBS
PBS-S10-020-PP-S-	10 X 1 1/4"	.365	6,000	6.9 LBS
PBS-S10-024-PP-S-	10 X 1 1/2"	.365	5,000	8.0 LBS

PLEASE NOTE OTHER SIZES AVAILABLE UPON REQUEST. PLEASE FEEL FREE TO INQUIRE.



TITAN HARDWARE INTERNATIONAL

7711 AMIGOS AVE, SUITE C, DOWNEY, CA 90242
LOCAL PH 562-803-1695 FAX 562-803-6605
EMAIL SALES@TITANHARDWARE.COM

GRAB-TITE SCREWS

FLAT HEADS WITH NIBS

TM

MATERIAL = HEAT TREATED STEEL

AVAILABLE PLATING

BLACK OXIDE (BW)

ZINC (CZ)

**PLEASE INCLUDE TWO DIGIT
CODE AT END OF PART # TO
SPECIFY PLATING.**

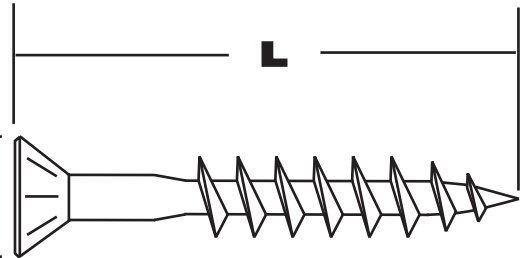

GRAB-TITE PARTICLE BOARD SCREWS COMBINE THE BEST FEATURES OF DRYWALL SCREWS AND WOOD SCREWS IN ONE FASTENER. THEY ARE FULL BODY AND HARDENED FOR SUPERIOR STRENGTH. THEY HAVE DEEP, COARSE THREADS FOR FAST DRIVING AND SUPERIOR HOLDING STRENGTH, AND THEY ALSO HAVE SELF COUNTERSINKING NIBS UNDERNEATH THE HEAD. ALL THESE FEATURES MAKE THE PERFECT SCREWS FOR FINISH CARPENTRY WORK.

PART NUMBER	SIZE & L	H	QUANTITY PER CTN.	WEIGHT. PER M
PBS-S08-012-PFN-S-	8 X 3/4"	.315	15,000	3.0 LBS
PBS-S08-016-PFN-S-	8 X 1"	.315	12,000	4.2 LBS
PBS-S08-020-PFN-S-	8 X 1 1/4"	.315	10,000	4.6 LBS
PBS-S08-024-PFN-S-	8 X 1 1/2"	.315	9,000	5.4 LBS
PBS-S08-026-PFN-S-	8 X 1 5/8"	.315	7,000	5.9 LBS
PBS-S08-028-PFN-S-	8 X 1 3/4"	.315	6,000	6.2 LBS
PBS-S08-032-PFN-S-	8 X 2"	.315	5,000	7.2 LBS
PBS-S09-016-PFN-S-	9 X 1"	.345	9,000	4.2 LBS
PBS-S09-024-PFN-S-	9 X 1 1/2"	.345	5,500	5.9 LBS
PBS-S09-028-PFN-S-	9 X 1 3/4"	.345	4,000	6.9 LBS
PBS-S09-040-PFN-S-	9 X 2 1/2"	.345	2,300	9.6 LBS
PBS-S09-048-PFN-S-	9 X 3"	.345	1,500	11.4 LBS

PLEASE NOTE OTHER SIZES AVAILABLE UPON REQUEST. PLEASE FEEL FREE TO INQUIRE.

9/15/00 **TOLL FREE PH 1-888-551-0456 FAX 1-888-551-0454**

WWW.TITANHARDWARE.COM

002-012



TITAN HARDWARE INTERNATIONAL

7711 AMIGOS AVE, SUITE C, DOWNEY, CA 90242
 LOCAL PH 562-803-1695 FAX 562-803-6605
 EMAIL SALES@TITANHARDWARE.COM

GRAB-TITE SCREWS

FLAT HEADS, NO NIBS

TM

MATERIAL = HEAT TREATED STEEL

AVAILABLE PLATING

BLACK OXIDE (BW)

ZINC (CZ)

**PLEASE INCLUDE TWO DIGIT
 CODE AT END OF PART # TO
 SPECIFY PLATING.**

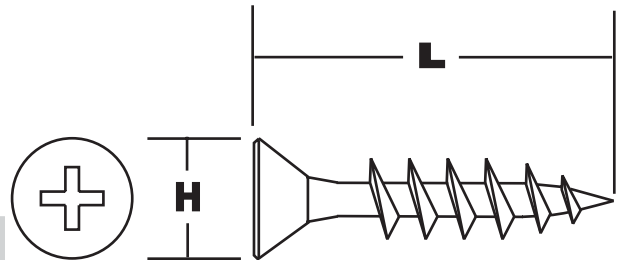

GRAB-TITE PARTICLE BOARD SCREWS COMBINE THE BEST FEATURES OF DRYWALL SCREWS AND WOOD SCREWS IN ONE FASTENER. THEY ARE FULL BODY AND HARDENED FOR SUPERIOR STRENGTH. THEY HAVE DEEP, COARSE THREADS FOR FAST DRIVING AND SUPERIOR HOLDING STRENGTH, THE FOLLOWING SIZES ARE AVAILABLE WITHOUT NIBS FOR MOUNTING HINGES AND MENDING PLATES.

PART NUMBER	SIZE & L	H	QUANTITY PER CTN.	WEIGHT. PER M
PBS-S05-010-PF-S-	5 X 5/8"	.197	30,000	2.5 LBS
PBS-S06-010-PF-S-	6 X 5/8"	.242	30,000	2.5 LBS
PBS-S08-010-PF-S-	8 X 5/8"	.315	24,000	3.5 LBS
PBS-S10-012-PF-S-	10 X 3/4"	.375	16,000	4.5 LBS

PLEASE NOTE OTHER SIZES AVAILABLE UPON REQUEST. PLEASE FEEL FREE TO INQUIRE.



TITAN
HARDWARE INTERNATIONAL
 7711 AMIGOS AVE, SUITE C, DOWNEY, CA 90242
 LOCAL PH 562-803-1695 FAX 562-803-6605
 EMAIL SALES@TITANHARDWARE.COM

GRAB-TITE CUTTERS™

NIBBED FLAT HEAD WITH WOOD CUTTING POINT

MATERIAL = HEAT TREATED STEEL

AVAILABLE PLATING

BLACK OXIDE (BW)
 ZINC (CZ)

PLEASE INCLUDE TWO DIGIT CODE AT END OF PART # TO SPECIFY PLATING.

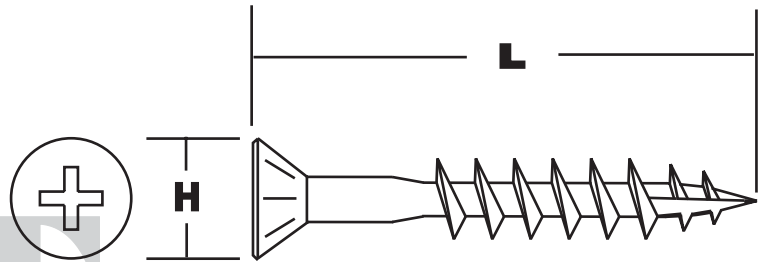

GRAB-TITE CUTTERS ARE SIMILAR TO DRYWALL SCREWS YET SUPERIOR IN SEVERAL WAYS. THEY ARE FULL BODY FOR SUPERIOR STRENGTH. THEY HAVE A SELF THREADING TYPE 17 POINT. AND THEY ALSO HAVE SELF COUNTERSINKING NIBS UNDERNEATH THE HEAD. ALL THESE FEATURES MAKE THE PERFECT SCREW FOR FINISH CARPENTRY WORK.

PART NUMBER	SIZE & L	H	QUANTITY PER CTN.	WEIGHT PER LBS
PB17-S08-020-PFN-S-	8 X 1 1/4"	.315	9,000	4.58 LBS
PB17-S08-024-PFN-S-	8 X 1 1/2"	.315	7,000	5.21 LBS
PB17-S08-026-PFN-S-	8 X 1 5/8"	.315	6,000	6.23 LBS
PB17-S08-032-PFN-S-	8 X 2"	.315	5,000	6.82 LBS
PB17-S09-040-PFN-S-	9 X 2 1/2"	.315	2,500	9.6 LBS
PB17-S09-048-PFN-S-	9 X 3"	.330	2,000	11.0 LBS

PLEASE NOTE OTHER SIZES AVAILABLE UPON REQUEST. PLEASE FEEL FREE TO INQUIRE.



TITAN
HARDWARE INTERNATIONAL
 7711 AMIGOS AVE, SUITE C, DOWNEY, CA 90242
 LOCAL PH 562-803-1695 FAX 562-803-6605
 EMAIL SALES@TITANHARDWARE.COM

ACCU-GLIDE™

SCREWS

MATERIAL = STEEL
AVAILABLE PLATING
 ZINC (CZ)
 BLACK OXIDE (BW)

**PLEASE INCLUDE TWO DIGIT
 CODE AT END OF PART # TO
 SPECIFY PLATING.**

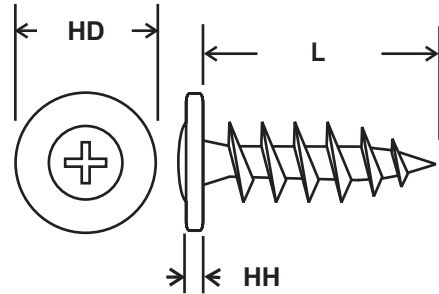

PMT

PT6

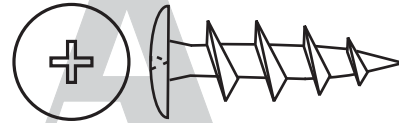

ACCU-GLIDE SCREWS ARE DESIGNED TO BE USED IN DRAWER GLIDE APPLICATIONS WHERE A LOW PROFILE HEAD IS A MUST.

PART NUMBER	SIZE & L	HD	HH	QUANTITY PER CTN.	WEIGHT PER M
TSAG-S08-PT6-S-	8 X 7/16"	.30	.072	20M	2.00LBS
TSAG-S08-PMT-S-	8 X 7/16"	.35	.100	18M	2.35 LBS

PLEASE NOTE OTHER SIZES AVAILABLE UPON REQUEST. PLEASE FEEL FREE TO INQUIRE.

9/15/00

TOLL FREE PH 1-888-551-0456 FAX 1-888-551-0454

WWW.TITANHARDWARE.COM

002-015



TITAN HARDWARE INTERNATIONAL

7711 AMIGOS AVE, SUITE C, DOWNEY, CA 90242
 LOCAL PH 562-803-1695 FAX 562-803-6605
 EMAIL SALES@TITANHARDWARE.COM

DRYWALL SCREWS

MATERIAL = HEAT TREATED STEEL

AVAILABLE PLATING

BLACK PHOSPHATE (RW)
 ZINC (CZ)
 YELLOW ZINC (YZ)
 ZARTAN (ZZ)

**PLEASE INCLUDE TWO DIGIT
 CODE AT END OF PART # TO
 SPECIFY PLATING.**

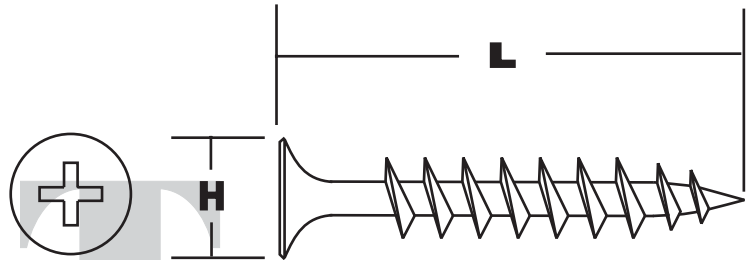

DRYWALL SCREWS WERE ORIGINALLY DESIGNED FOR THE CONSTRUCTION INDUSTRY. HOWEVER, THEIR HIGH STRENGTH, DEEP THREADS AND LOW PROFILE HEADS MAKE THEM THE PERFECT CHOICE FOR A VARIETY OF FURNITURE ASSEMBLY APPLICATIONS.

PART NUMBER	SIZE & L	H	MAJOR DIAMETER	QUANTITY PER CTN.	G. W. PER CTN
DWC-S06-016-PB-S-	6 X 1"	.330	.148	10,000	28.1 LBS
DWC-S06-020-PB-S-	6 X 1 1/4"	.330	.148	8,000	29.2 LBS
DWC-S06-024-PB-S-	6 X 1 1/2"	.330	.148	6,000	23.6 LBS
DWC-S06-026-PB-S-	6 X 1 5/8"	.330	.148	5,000	21.7 LBS
DWC-S06-032-PB-S-	6 X 2"	.330	.148	3,500	19.8 LBS
DWC-S06-036-PB-S-	6 X 2 1/4"	.330	.148	3,000	18.5 LBS
DWC-S07-032-PB-S-	7 X 2"	.335	.165	3,500	23.1 LBS
DWC-S08-040-PB-S-	8 X 2 1/2"	.348	.172	2,500	24.4 LBS
DWC-S08-048-PB-S-	8 X 3"	.348	.172	2,000	21.9 LBS
DWF-S10-064-PB-S-	10 X 4"	.385	.195	1,000	21.5 LBS
DWF-S10-060-PB-S-	10 X 5"	.385	.172	600	23.6 LBS

12/15/99

TOLL FREE PH 1-888-551-0456 FAX 1-888-551-0454

WWW.TITANHARDWARE.COM

002-016



TITAN HARDWARE INTERNATIONAL

7711 AMIGOS AVE, SUITE C, DOWNEY, CA 90242
LOCAL PH 562-803-1695 FAX 562-803-6605
EMAIL SALES@TITANHARDWARE.COM

HINGE SCREWS

FLAT HEAD TSA

MATERIAL = HEAT TREATED STEEL

AVAILABLE PLATING

STAT/BRONZE (SB)
BLACK OXIDE (BW)
BRIGHT BRASS (DB)
ANTIQUÉ BRASS (AB)
NICKEL (NI)
ZINC (CZ)
PLAIN FINISH (RW)

**PLEASE INCLUDE TWO DIGIT
CODE AT END OF PART # TO
SPECIFY PLATING.**

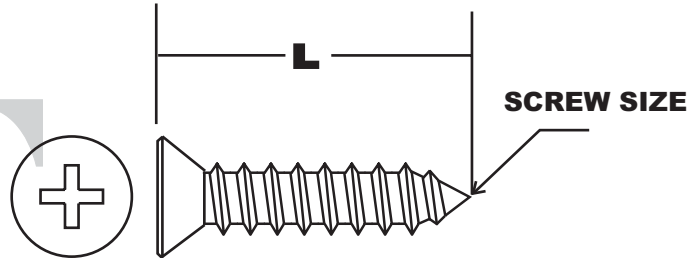

TYPE A HINGE SCREWS Offer finer threads than particle board screws which help in applications where the screws have to be installed and re-installed for adjusting, such as when installing drawer slides and hinges.

PART NUMBER	SIZE & L	QUANTITY PER CTN.	LBS PER M
TSA-S04-006-PF-S-	4 X 3/8"	25M	0.87
TSA-S04-008-PF-S-	4 X 1/2"	25M	1.03
TSA-S05-010-PF-S-	5 X 5/8"	25M	1.61
TSA-S06-007-PF-S-	6 X 7/16"	25M	1.36
TSA-S06-008-PF-S-	6 X 1/2"	25M	1.47
TSA-S06-010-PF-S-	6 X 5/8"	25M	1.91
TSA-S06-012-PF-S-	6 X 3/4"	25M	3.30
TSA-S08-010-PF-S-	8 X 5/8"	25M	2.75

PLEASE NOTE OTHER SIZES AVAILABLE UPON REQUEST. PLEASE FEEL FREE TO INQUIRE.

1/08/03 **TOLL FREE PH 1-888-551-0456 FAX 1-888-551-0454**

WWW.TITANHARDWARE.COM

002-017



TITAN
HARDWARE INTERNATIONAL
 7711 AMIGOS AVE, SUITE C, DOWNEY, CA 90242
 LOCAL PH 562-803-1695 FAX 562-803-6605
 EMAIL SALES@TITANHARDWARE.COM

HINGE SCREWS

FLAT HEADSTWINFAST

MATERIAL = HEAT TREATED STEEL

AVAILABLE PLATING

- STAT/BRONZE (SB)
- BLACK OXIDE (BW)
- BRIGHT BRASS (DB)
- ANTIQUE BRASS (AB)
- NICKEL (NI)
- ZINC (CZ)
- PLAIN FINISH (RW)

PLEASE INCLUDE TWO DIGIT CODE AT END OF PART # TO SPECIFY PLATING.

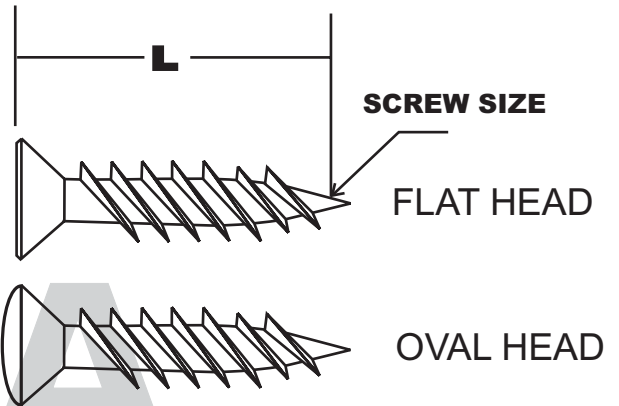

TWINFAST HINGE SCREWS Offer fine twin-lead threads at a more aggressive angle to speed up installation into hard woods.

PART NUMBER	SIZE & L	HEAD	QUANTITY PER CTN.	LBS PER M
TTF-S05-008-PF-S-	5 X 1/2"	FLAT	25M	1.0
TTF-S05-010-PF-S-	5 X 5/8"	FLAT	25M	1.6
TTF-S06-008-PF-S-	6 X 1/2"	FLAT	25M	1.5
TTF-S06-010-PF-S-	6 X 5/8"	FLAT	25M	1.9
TTF-S06-010-PO-S-	6 X 5/8"	OVAL	25M	2.2
TTF-S06-012-PF-S-	6 X 3/4"	FLAT	25M	3.3

PLEASE NOTE OTHER SIZES AVAILABLE UPON REQUEST. PLEASE FEEL FREE TO INQUIRE.

1/14/04 **TOLL FREE PH 1-888-551-0456 FAX 1-888-551-0454**

WWW.TITANHARDWARE.COM

002-018